



GENESIS 250/300 REAR SEAT WILL FIT CLUB CAR® PRECEDENT® INSTALLATION INSTRUCTIONS

INCLUDED:

- Hardware Packs 1-8
- Grab Bar
- Lean Back Brackets
- frame Bracket
- Armrests
- Footrest
- Main Frame
- struts

TOOLS NEEDED:

- Drill
- 17mm Socket
- 17mm Wrench
- 14mm Socket
- 10mm Select
- 3/8 Drill Bit
- #3 Phillips Tip
- 13mm Wrench

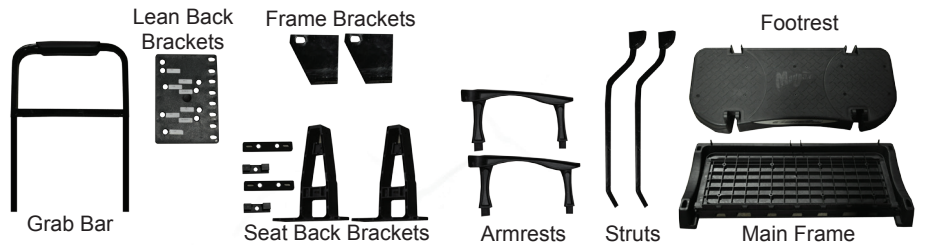

Madjax recommends professional installation. If you choose to not have this product installed by a professional, we highly recommend that you exercise caution, care, and patience when installing this product as it involves drilling holes into your cart's body.

1

Remove front seat hardware located behind seat. Remove front seat cushion. Retain hardware.



Remove upper rear canopy strut hardware. Use a prop to support canopy. Retain hardware.

2

Remove lower rear strut hardware located on inside of basket. Remove factory struts.

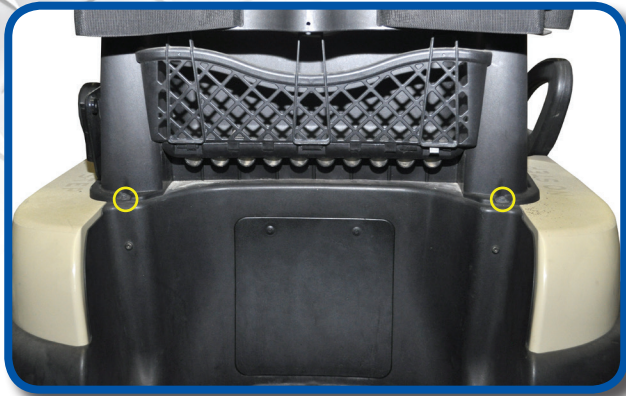

Remove hardware from base of basket. Two bolts are located in the rear and two bolts located in the front.

Remove hardware from basket retainer. Remove basket retainer. Retain hardware.

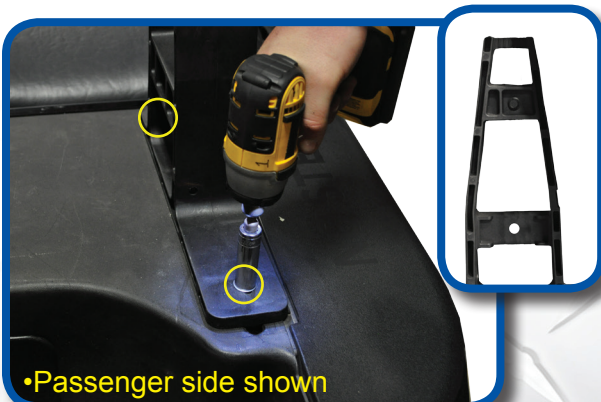

•Passenger side shown

Attach main brackets to cart using hardware from Pack 1 at same location as step 5.

Attach (corner support bracket's) to main bracket as shown using hardware from pack 1.

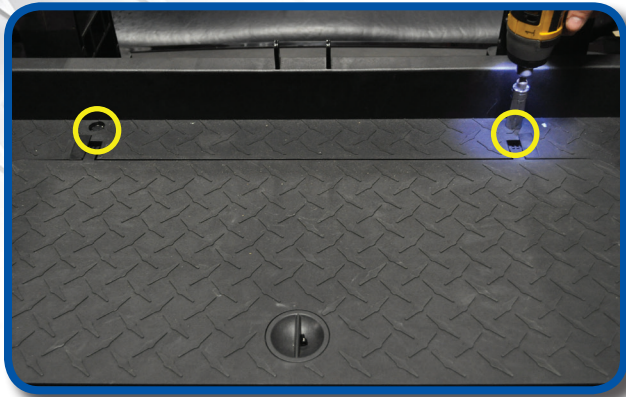
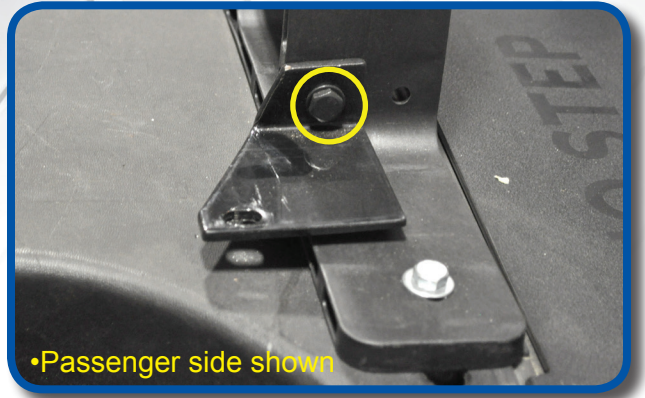

Attach main seat Frame to Frame/ Corner Bracket's using hardware from Pack 2.

Attach bagwell bracket to poly seat frame using hardware from Pack 2 as shown. Do not tighten.



With bagwell bracket resting on bumper, align rear bracket to center of cart, use a marking pen to mark drilling locations.

11
Using a "3/8" drill bit, gently drill through back bumper as shown.



12
Using a #3 phillips head bit, attach bagwell bracket to cart using hardware from Pack 3.

13
Attach arm rest to poly seat frame as shown using hardware from Pack 4.



•Driver side shown

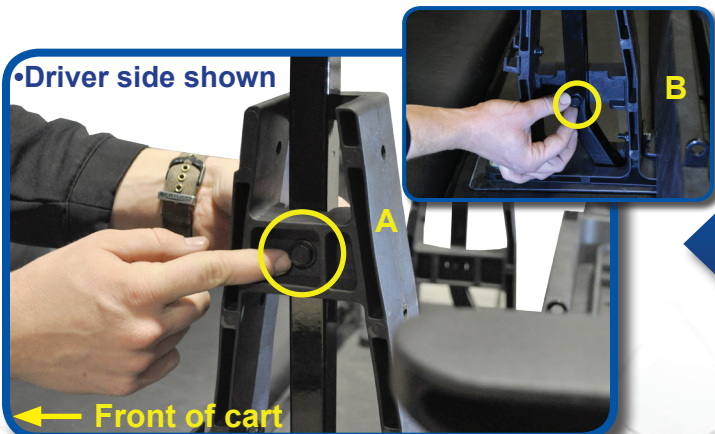

14
Place rear struts through main seat brackets as shown, use provided hardware remaining from Pack 1. Repeat process on other side.

A) Top of main bracket should align to outside of cart as shown.

B) Base of main bracket should align to inside of strut as shown.

15
Using the appropriate labeled hole for your cart, attach lean back bracket to main seat bracket using hardware from Pack 5.

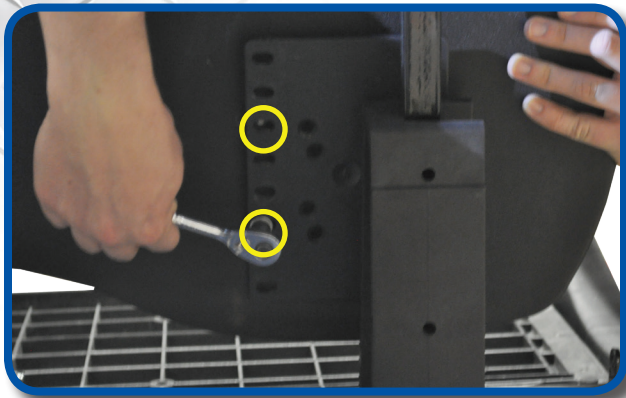
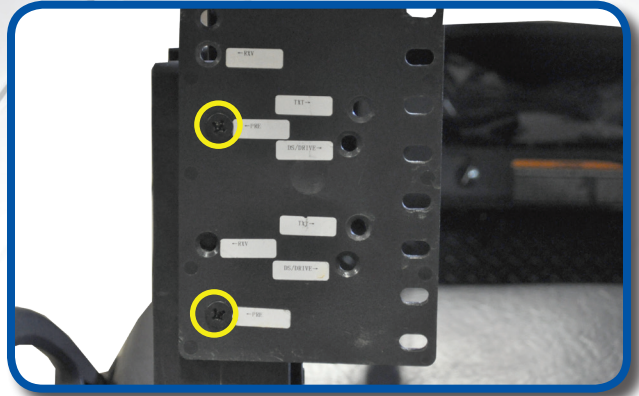

16
Choose desired height and attach cushion to lean back bracket using hardware from Pack 6.

17
Attach seat support strip to front of seat back bracket as shown using hardware from Pack 6.

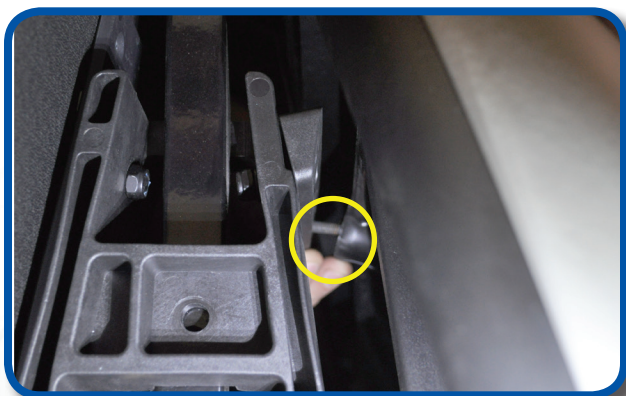
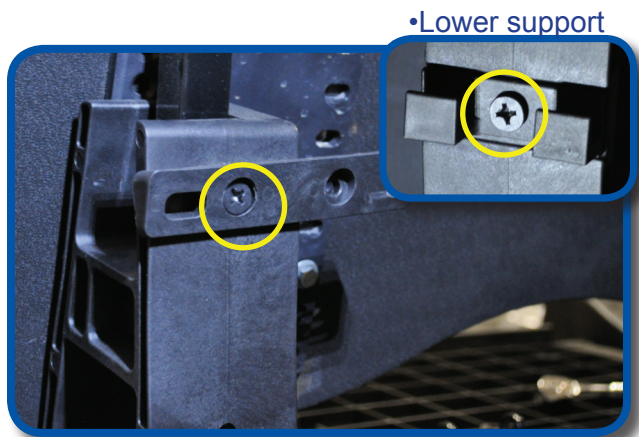

18
Attach seat back cushion using hardware retained from Step 1 as shown.

19
Attach footrest to bracket as shown using 10mm hardware from pack 7. Repeat process on other side.

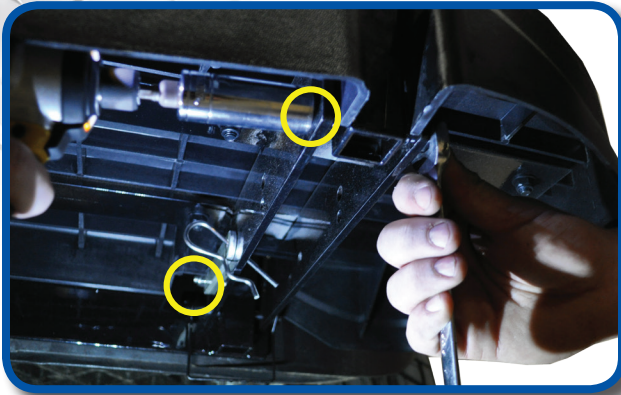

20
Attach grab bar to footrest as shown using 10mm hardware from pack 7. Repeat process on other side.

21
Secure footplate and grab bar as shown with quick release clip from hardware Pack 7.



22
Attach seat bottom cushion as shown using hardware from Pack 8.

23

Re attach roof to rear struts using hardware retained from Step 2.



24

Footplate can be folded up by removing the four quick release clips and folding forward. To lock footplate in up right poistion use brackets as shown.



INSTALLATION COMPLETE

VISIT WWW.MYMADJAX.COM FOR MORE INSTALLATION VIDEOS.

Club Car®, Club Car® Precedent®, and Club Car® DS® are registered trademarks of Ingersoll Rand, Inc. ("Ingersoll Rand"). Reference to Club Car®, Club Car® Precedent®, or Club Car® DS® or any of Ingersoll Rand's trademarks, word marks, or products is only for purposes of identifying golf carts with which this Madjax product is compatible. Madjax products are aftermarket parts and are not original equipment parts. Madjax is not connected to, affiliated with, sponsored by, or endorsed by Ingersoll Rand or any of its subsidiary companies.

HARDWARE PACKS

Pack 1

- 8 – 8x45mm hex bolt
- 2 – 8x40mm hex bolt
- 16 – 8x20mm Flat washers
- 6 – 8mm locknuts
- 6 – Rubber Washers

Pack 2

- 2 – 8x55mm hex bolt
- 4 – 8x15mm flat washer
- 2 – 8mm lock nut
- 2 – 10x50mm Hex bolt
- 4 – 10x20mm Flat washer
- 2 – 10mm Lock nut
- 8 – Rubber Washers

Pack 3

- 2 – 10x70mm Countersunk #3 Phillips
- 2 – 10x20mm flat washer
- 2 – 10mm lock nut
- 2 – Rubber Washers

Pack 4

- 4 – 8x30mm hex bolt
- 4 – 8x15mm flat washer

Pack 5

- 4 – 8x35mm countersunk #3 Phillips
- 4 – 8x15mm flat washer
- 4 – 8mm locknut

Pack 6

- 4 – 6x25mm hex bolt
- 4 – 6x15mm flat washer
- 4 – 6mm lock washer
- 4 – 8x30mm countersunk #3 Phillips
- 4 – 8mm Lock nut
- 4 – 8x17mm flat washer

Pack 7

- 4 – 10x75mm hex bolt
- 8 – 10x20mm flat washer
- 4 – 10mm Locknut
- 4 – Quick release pins (easy remove hardware for folding in the foot plate)
- 4 – Rubber Washers

Pack 8

- 8 – 8x40mm countersunk

